

STRATUS™

TENSIONER PUMP

Stratus™—Designed for the punishing conditions and demanding requirements of wind turbine bolt tensioning.

Extreme temperatures. Rough handling. Low voltage. Dust and dirt. High duty cycles.

These are just a few of the challenges that an Electric Tensioner Pump must overcome.

The Stratus Electric Tensioner Pump is designed around the following principles:

SAFETY

Low voltage hand pendant control circuit; emergency stop on pendant; backup pressure release button for releasing trapped pressure even if power is lost.

RELIABILITY

Robust industrial electric motor handles heat and low voltage challenges typically found on West Texas wind farms. Every unit is subjected to rigorous cycle testing to verify performance and reliability. Advanced filtration designed to protect hydraulics.

DURABILITY

Stratus comes with a protective frame as a standard feature. The hydraulic circuit is designed for a long system life and less heat generation.

USABILITY

Compact size and low weight; operator controls designed to deliver higher efficiency for bolting operations.



SPEED

More horsepower means more flow at high pressure.

Designed and assembled in USA.

STRATUS PRODUCT RANGE AND OPTIONS

- Pressures up to 30,000 psi available*
- Double-acting circuits available
- Removable digital gauge optional
- Oil cooler optional
- Larger reservoir sizes available
- Larger horsepower models available
- Alternative fluid / water-glycol compatible models available

*Custom configurations up to 72,000 psi available

STRATUS™ TENSIONER PUMP

SPECIFICATIONS

Horse Power	1.5 HP
Full Load Amps (120/240 VAC)	13.2 A / 6.6 A
Weight	73 lbs. (dry) including frame
Size	Frame dimensions: 16" L x 13.6" W x 22.75" H
Cage Protection	Standard. No additional cost.
Controls	Comes standard with hand pendant. Pendant controls include: pressure up, pressure release and system on/off. Pendant comes with 20' cord.
Reservoir Capacity	Up to 1.5 gallons useable

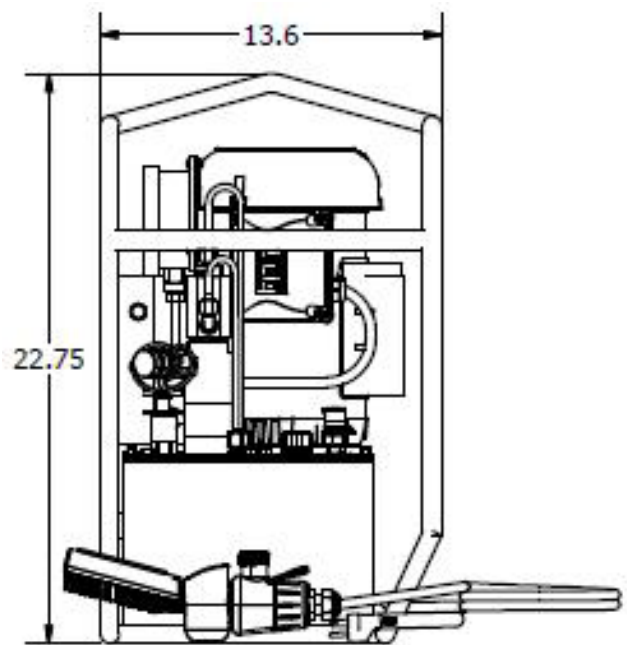
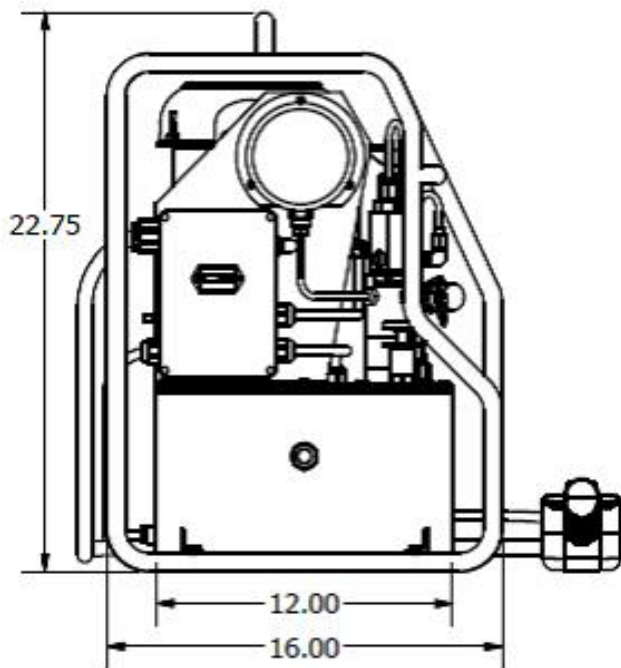

MODEL CHARACTERISTICS

DIMENSIONS

- 16.0"L x 13.6"W x 22.75"H
- Weight: 73 lbs. (Dry)

ELECTRICAL

- 120 Volts AC, 1 Phase
- 240 Volts AC, 1 Phase
- 240 Volts AC, 3 Phase
- 480 Volts AC, 3 Phase

HAND PENDANT

- On/Off, Pressure Up & Pressure Release Buttons

HYDRAULIC

- Reservoir 1+ gallon (usable) with Sight Gauge and Drain
- User Adjustable Pressure Control Valve
- Calibratable Analog Gauge. Digital Gauge optional
- Factory Pre-Set Pressure Safety Valve
- Low Voltage DC Control Circuit

FILTRATION

- Synthetic Pressure Filter
- Air Breather Filter